

Aisin A650E 5Speed

Last Changed: 25/04/2022 Page 1 of 2

Harness Required: OT01-P1, OT03-P2, E36, DB2 Negative, CON2

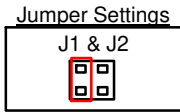
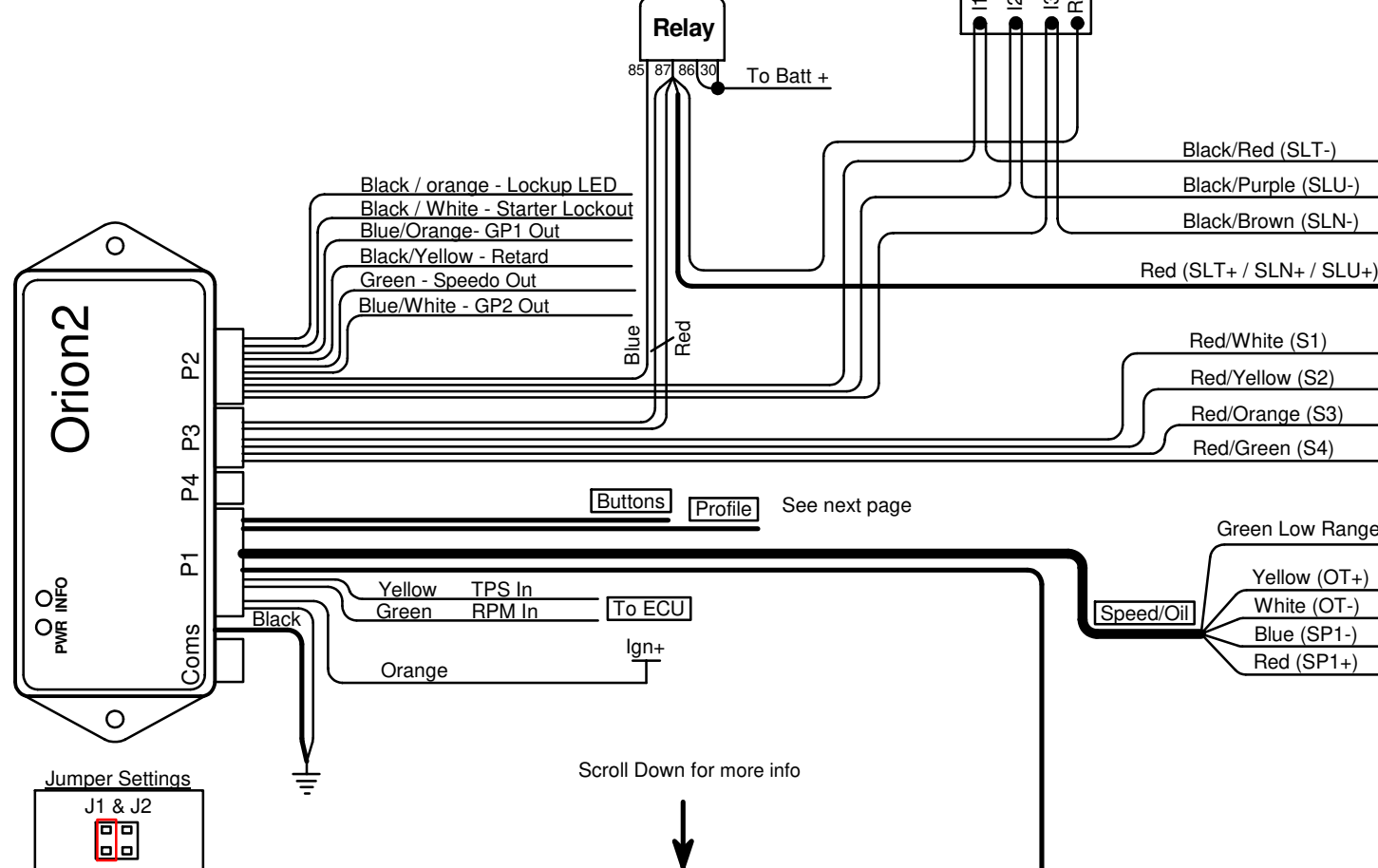

Scroll Down for more info

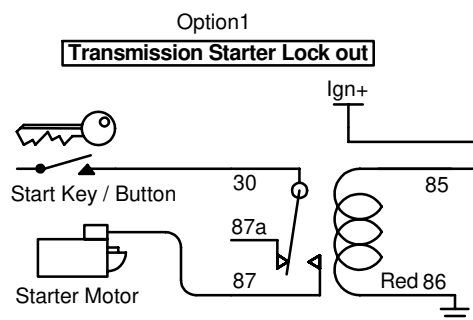
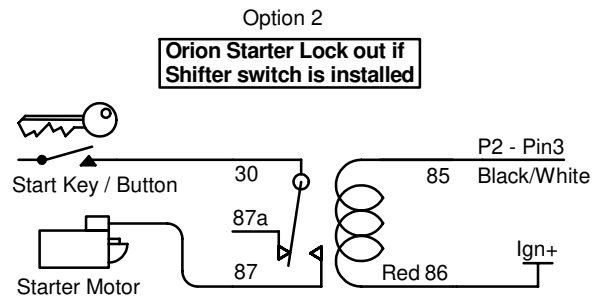

Transmission Connector

NB! Harness Plug Pin View

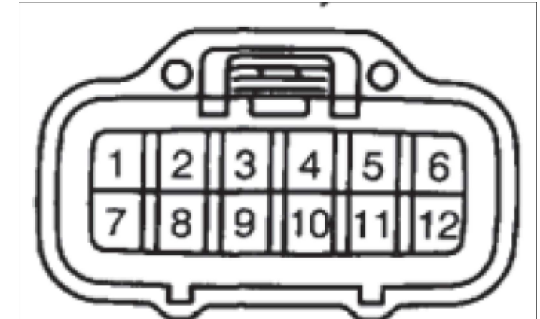

Pin	Harness	Color	Connector	Resistance	
				Cold	Hot
1	Oil Temp	OT-	Black	P1-Gnd	
2	12V	SLT-	Red		
3	12V	SLN-	Red		
4	12V	SLU-	Red		
5	Gearbox	S3	Red/Orange	P3-6	11 18 Ω
6	Gearbox	S1	Red/White	P3-5	11 18 Ω
7	Oil Temp	OT+	Yellow	P1-1	
8	Gearbox	SLT+	Black/Red	DB2 (P2-6)	3.5 4.6 Ω
9	Gearbox	SLN+	Black/Brown	DB2 (P2-7)	3.5 4.6 Ω
10	Gearbox	SLU+	Black/Purple	DB2 (P2-1)	3.5 4.6 Ω
11	Gearbox	S4	Red/Green	P3-2	11 18 Ω
12	Gearbox	S2	Red/Yellow	P3-1	11 18 Ω

Magnetic Speed Sensor

NB! Harness Plug Pin View

				Cold Hot	
1	Speed	SP1+	Red	P1-5	560 680 Ω
2	Speed	SP1-	Blue	P1-11	



Transmission Selector Switch

NB! Harness Plug Pin View

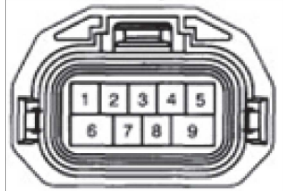
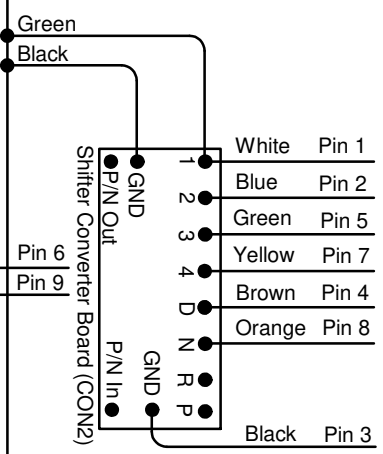

Aisin A650E 5Speed

Last Changed: 25/04/2022 Page 2 of 2

Harness Required: OT01-P1, OT03-P2, E36, DB2 Negative, CON2

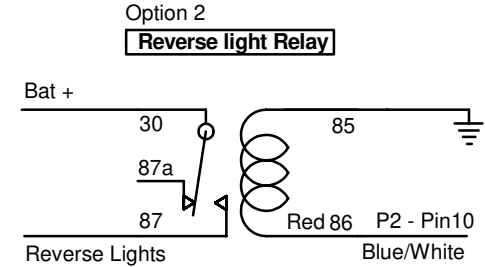
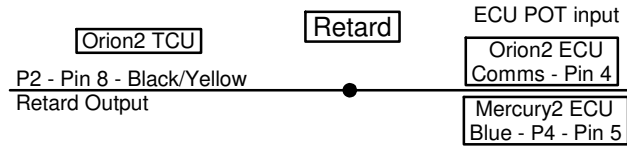

Note this feature share the GP1 output. Put the GP1 output off in software to use it.

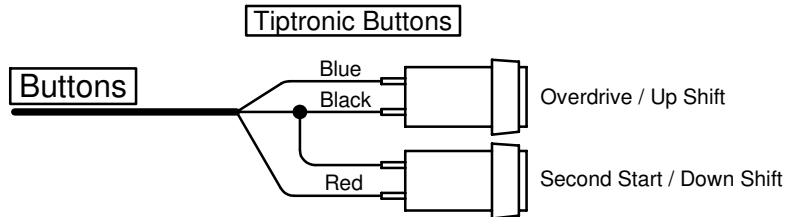

Note this feature requires the OT20 Harness. Ensure that the jumper settings is corect for it.

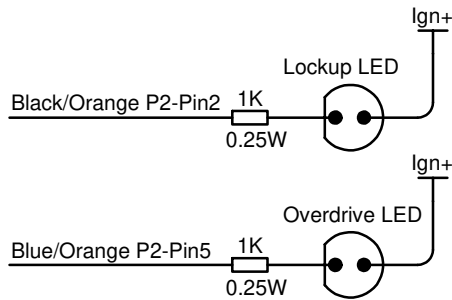
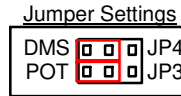

NB! Resistors are required for LED's

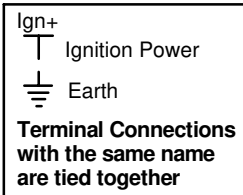

Note: Harnesses pin-outs and colours are layed out on the GP Priority Sheet

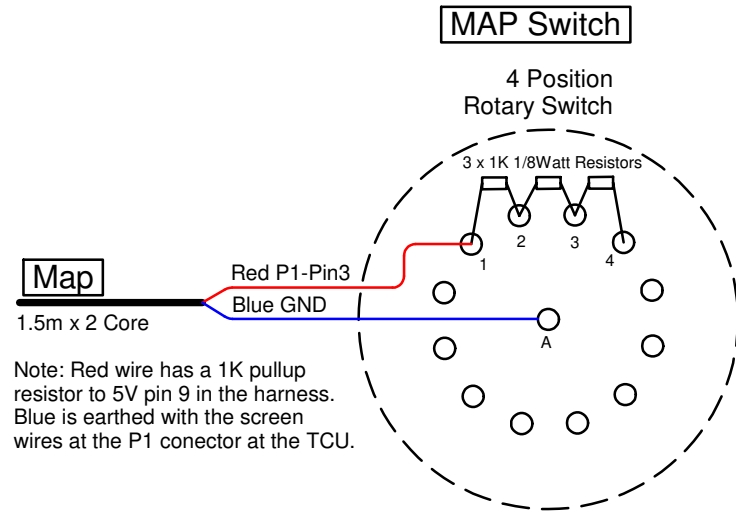

Note: Red wire has a 1K pullup resistor to 5V pin 9 in the harness. Blue is earthed with the screen wires at the P1 conector at the TCU.