

Speed Sensor Wiring

Harness: MTSX02-2 or MTWX02-2
 Last Changed: 26/02/2026

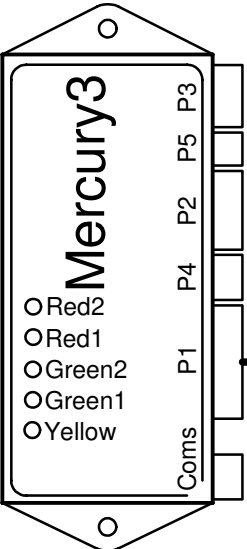

Magnetic Speed Sensor

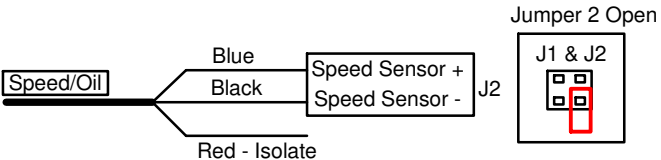

Hall or Optic Speed Sensor

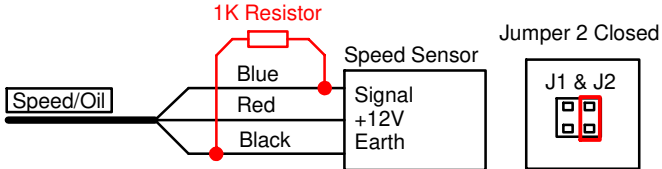

Note! Optional 1 K resistors from signal to earth will help prevent interference from the ECU supply voltage

Magnetic Speed Sensor Tap-In and filter

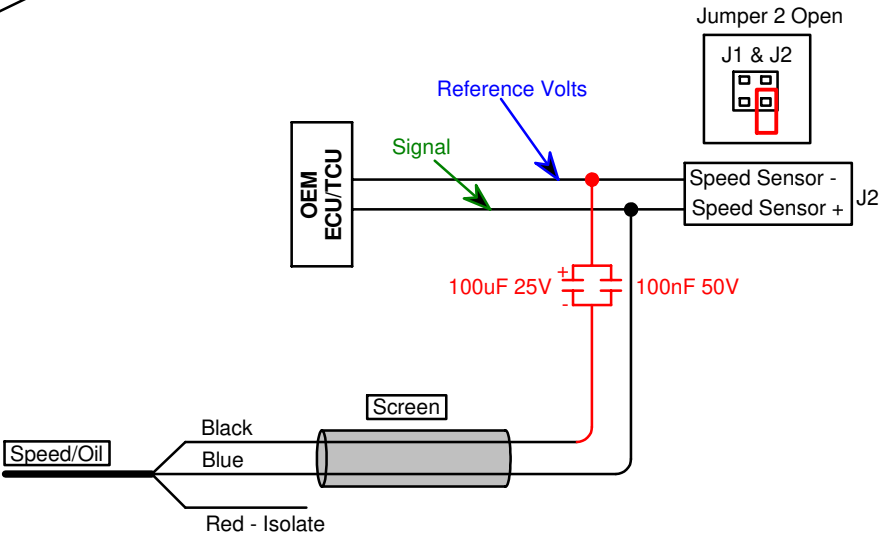

Note! Optional Capacitors from reference to black will help prevent interference in ECU earth differences

Hall or Optic or Tacho Speed Sensor Tap-In and filter

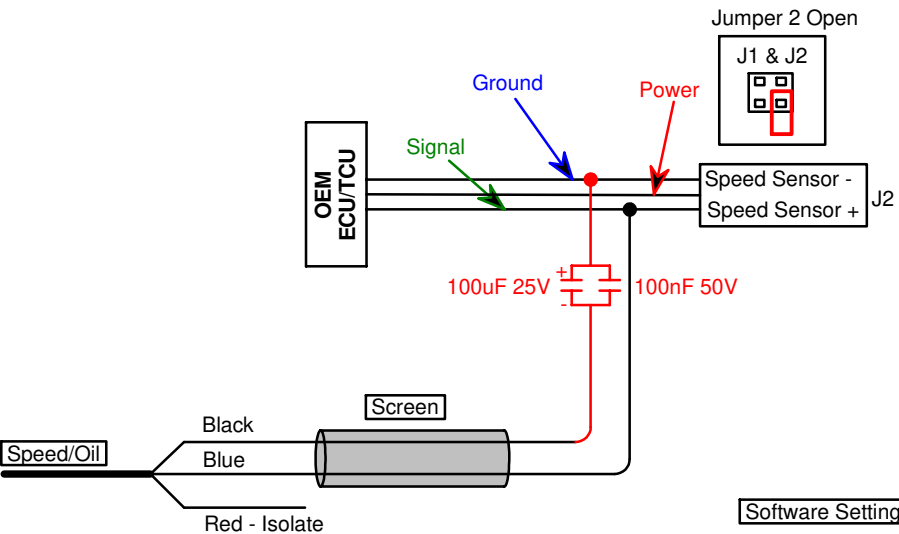

Note! Optional Capacitors from reference to black will help prevent interference in ECU earth differences

Software Settings

- Active Sensors**
- RPM
 - Speed