

# EZ62B Callisto ECU Default Jumper Settings

Last Changed: 18/04/2026

PCB: EZ62B

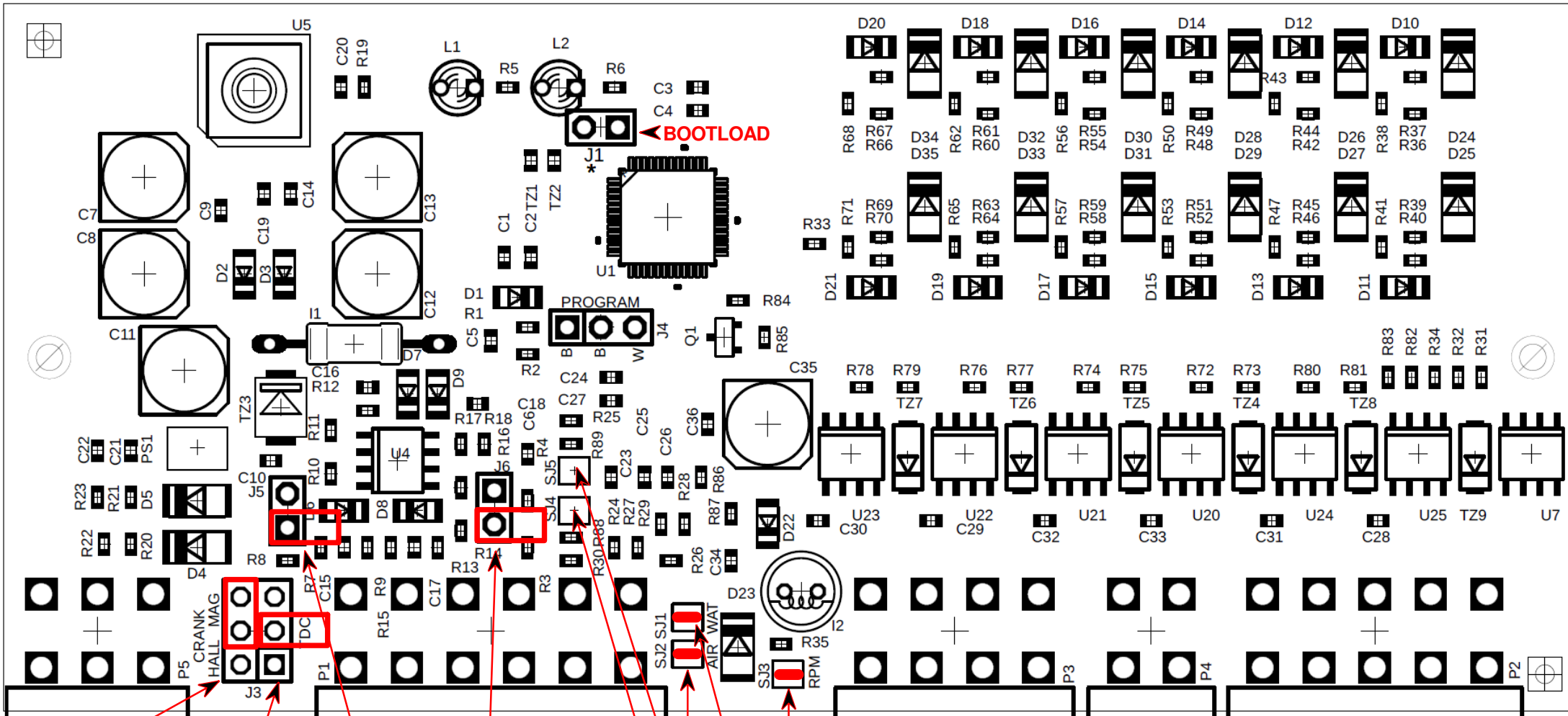

**Crank Sensor**  
Up - Magnetic  
Down - Hall

**Cam Sensor**  
Up - Magnetic  
Down - Hall

**Crank Sensor**  
Off - Magnetic  
On - Hall Pullup

**Cam Sensor**  
Off - Magnetic  
On - Hall Pullup

**Solder Jumpers ECU**  
SJ1 = Water Sensor Pullup - **Close**  
SJ2 = Air Sensor Pullup - **Close**  
SJ3 = RPM Pullup - **Close**  
SJ4 = Lambda Pullup - **Open**  
SJ5 = Map Pullup - **Open**

# EZ62B Callisto 1xMagnetic Jumper Settings

Last Changed: 18/04/2026

PCB: EZ62B

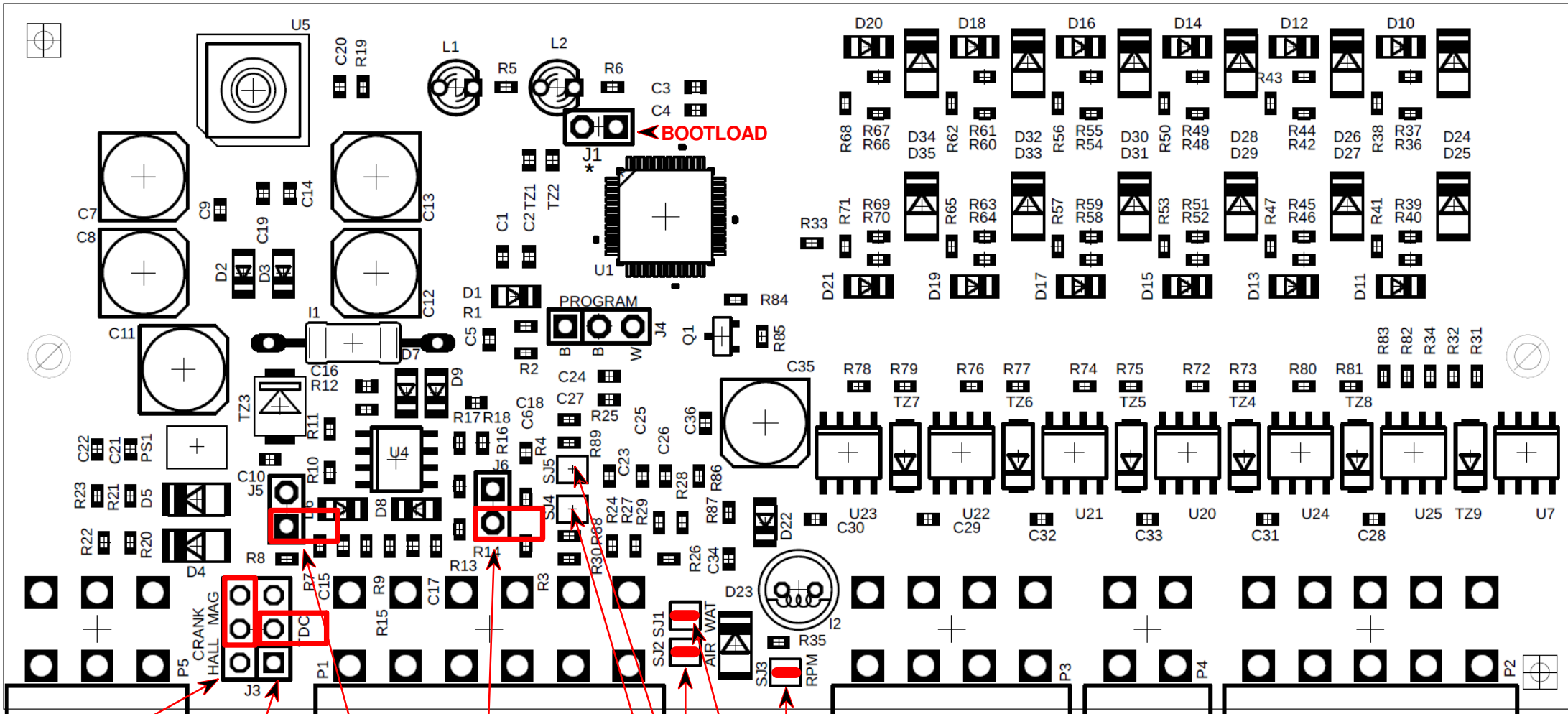

**Crank Sensor**  
Up - Magnetic  
Down - Hall

**Cam Sensor**  
Up - Magnetic  
Down - Hall

**Crank Sensor**  
Off - Magnetic  
On - Hall Pullup

**Cam Sensor**  
Off - Magnetic  
On - Hall Pullup

**Solder Jumpers ECU**

SJ1 = Water Sensor Pullup - **Close**

SJ2 = Air Sensor Pullup - **Close**

SJ3 = RPM Pullup - **Close**

SJ4 = Lambda Pullup - **Open**

SJ5 = Map Pullup - **Open**

# EZ62B Callisto 2xMagnetic Jumper Settings

Last Changed: 18/04/2026

PCB: EZ62B

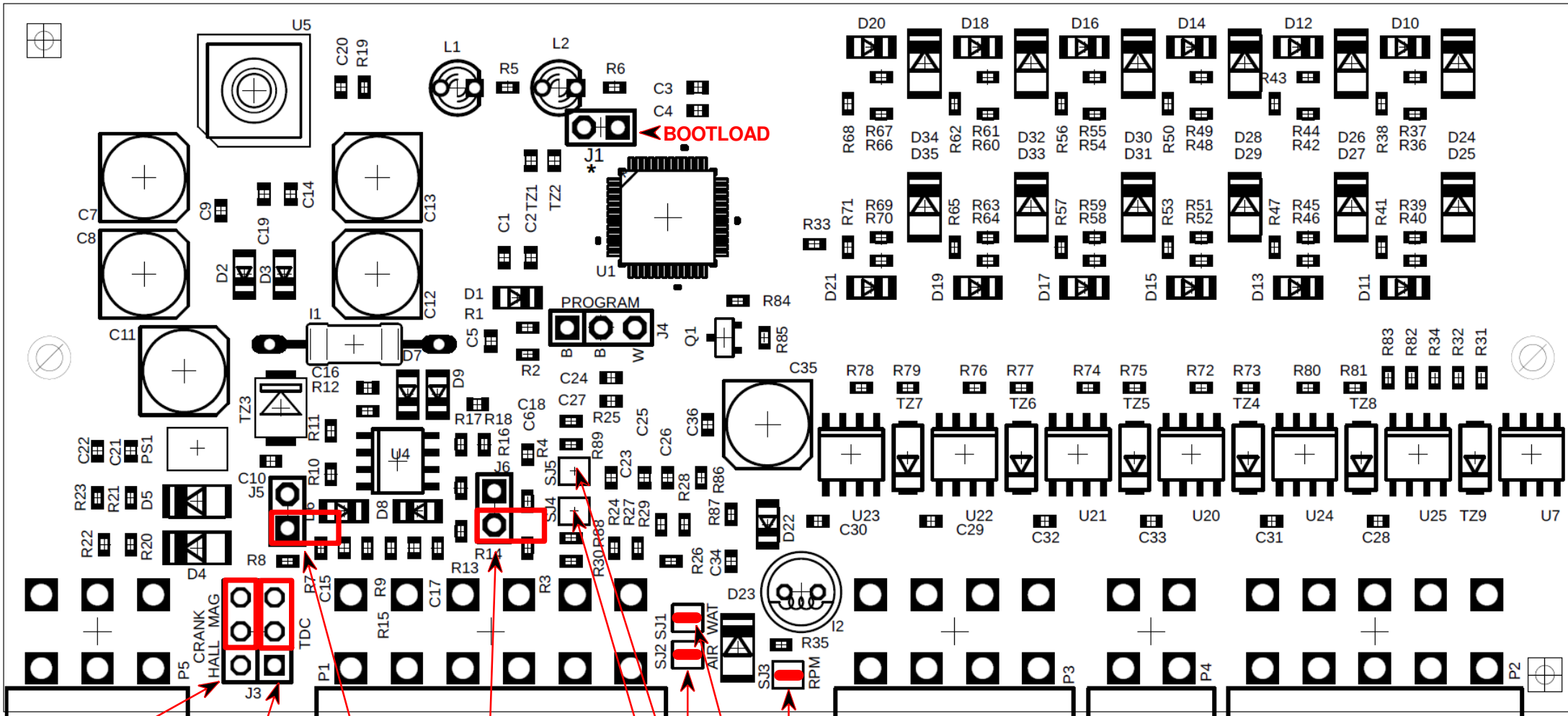

**Crank Sensor**  
Up - Magnetic  
Down - Hall

**Cam Sensor**  
Up - Magnetic  
Down - Hall

**Crank Sensor**  
Off - Magnetic  
On - Hall Pullup

**Cam Sensor**  
Off - Magnetic  
On - Hall Pullup

**Solder Jumpers ECU**  
SJ1 = Water Sensor Pullup - **Close**  
SJ2 = Air Sensor Pullup - **Close**  
SJ3 = RPM Pullup - **Close**  
SJ4 = Lambda Pullup - **Open**  
SJ5 = Map Pullup - **Open**

# EZ62B Callisto 1xHall Jumper Settings

Last Changed: 18/04/2026

PCB: EZ62B

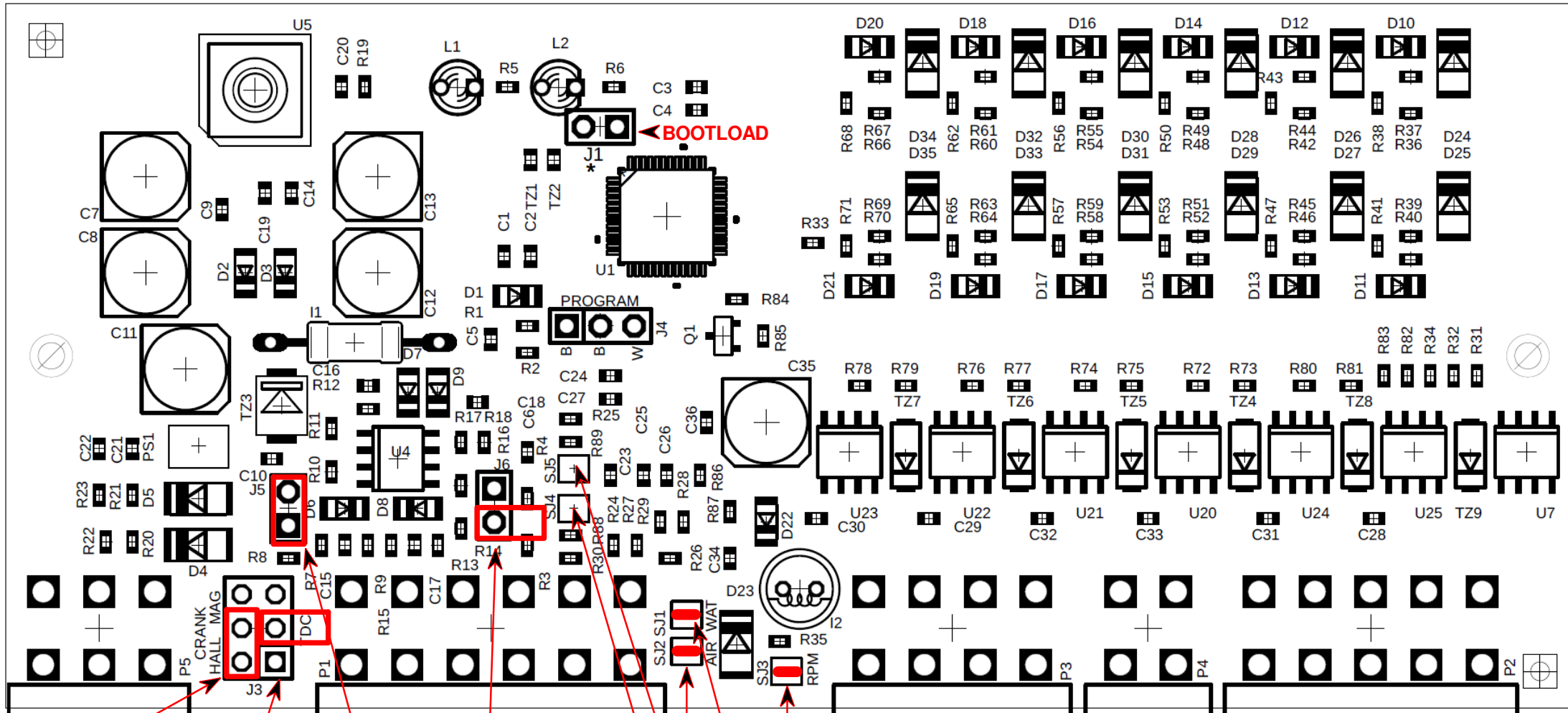

**Crank Sensor**  
Up - Magnetic  
Down - Hall

**Cam Sensor**  
Up - Magnetic  
Down - Hall

**Crank Sensor**  
Off - Magnetic  
On - Hall Pullup

**Cam Sensor**  
Off - Magnetic  
On - Hall Pullup

**Solder Jumpers ECU**  
SJ1 = Water Sensor Pullup - **Close**  
SJ2 = Air Sensor Pullup - **Close**  
SJ3 = RPM Pullup - **Close**  
SJ4 = Lambda Pullup - **Open**  
SJ5 = Map Pullup - **Open**

# EZ62B Callisto 2xHall Jumper Settings

Last Changed: 18/04/2026

PCB: EZ62B

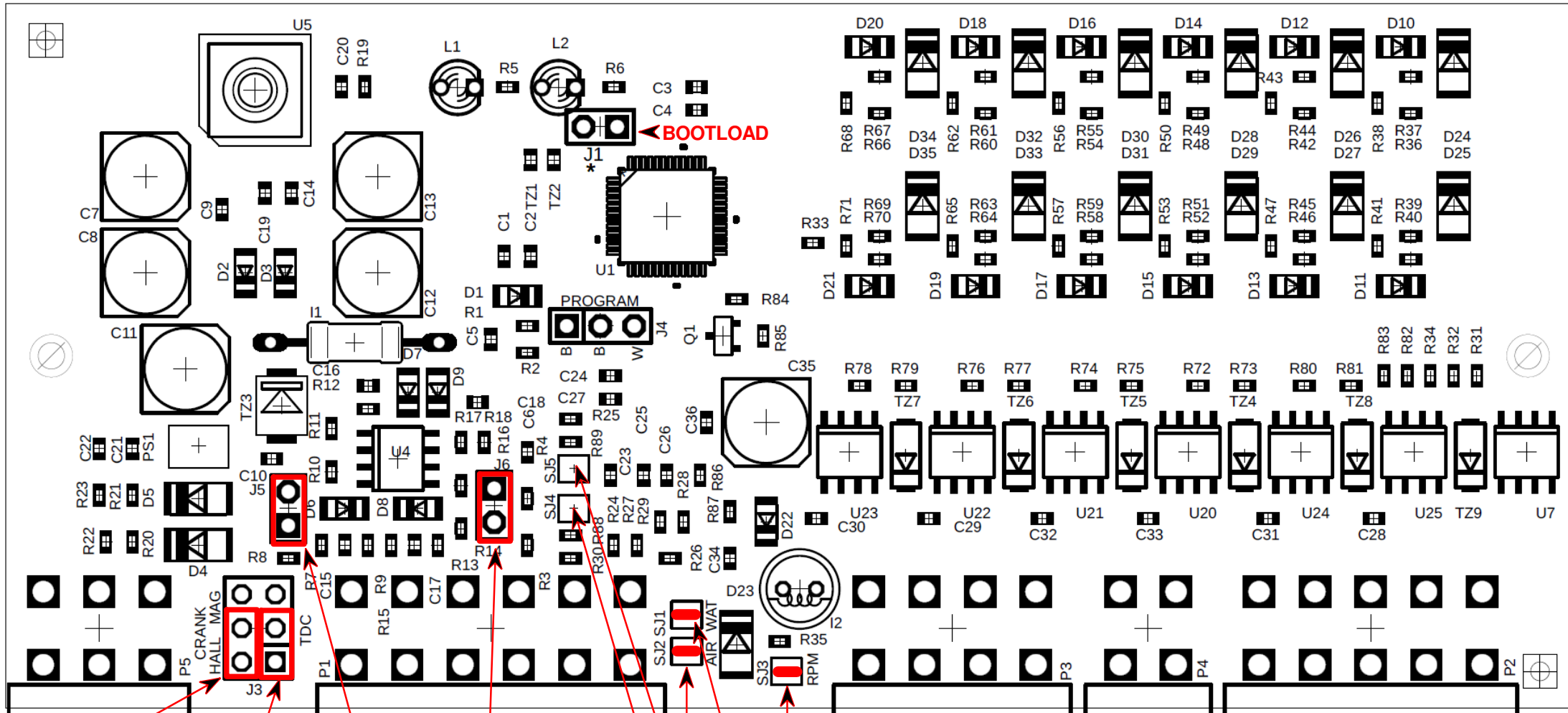

**Crank Sensor**  
Up - Magnetic  
Down - Hall

**Cam Sensor**  
Up - Magnetic  
Down - Hall

**Crank Sensor**  
Off - Magnetic  
On - Hall Pullup

**Cam Sensor**  
Off - Magnetic  
On - Hall Pullup

**Solder Jumpers ECU**

SJ1 = Water Sensor Pullup - **Close**

SJ2 = Air Sensor Pullup - **Close**

SJ3 = RPM Pullup - **Close**

SJ4 = Lambda Pullup - **Open**

SJ5 = Map Pullup - **Open**

# EZ62B Callisto 1x Magnetic 1xHall Jumper Settings

Last Changed: 18/04/2026

PCB: EZ62B

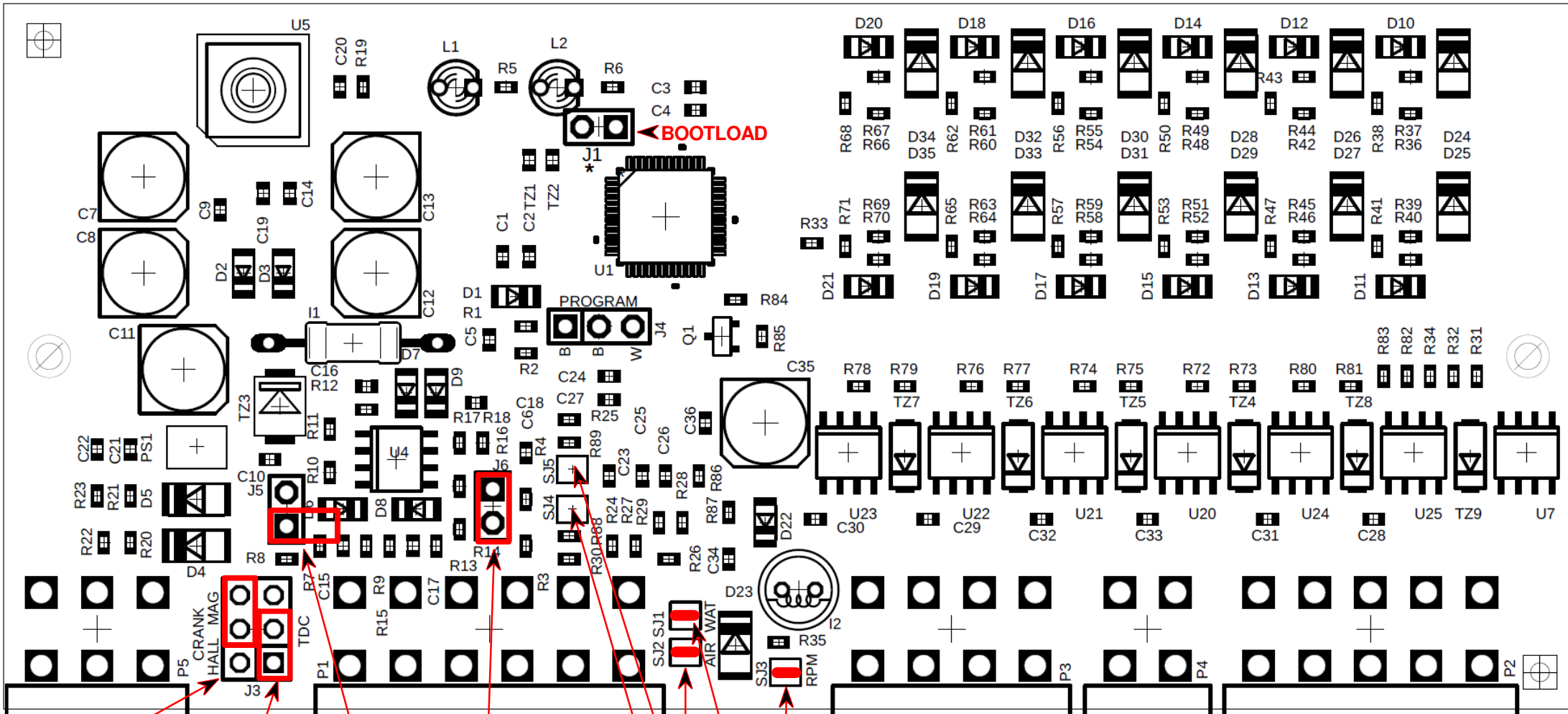

**Crank Sensor**  
Up - Magnetic  
Down - Hall

**Cam Sensor**  
Up - Magnetic  
Down - Hall

**Crank Sensor**  
Off - Magnetic  
On - Hall Pullup

**Cam Sensor**  
Off - Magnetic  
On - Hall Pullup

**Solder Jumpers ECU**

SJ1 = Water Sensor Pullup - **Close**

SJ2 = Air Sensor Pullup - **Close**

SJ3 = RPM Pullup - **Close**

SJ4 = Lambda Pullup - **Open**

SJ5 = Map Pullup - **Open**