

# Handshake with Mercury TCU

Last Changed: 22/10/2025

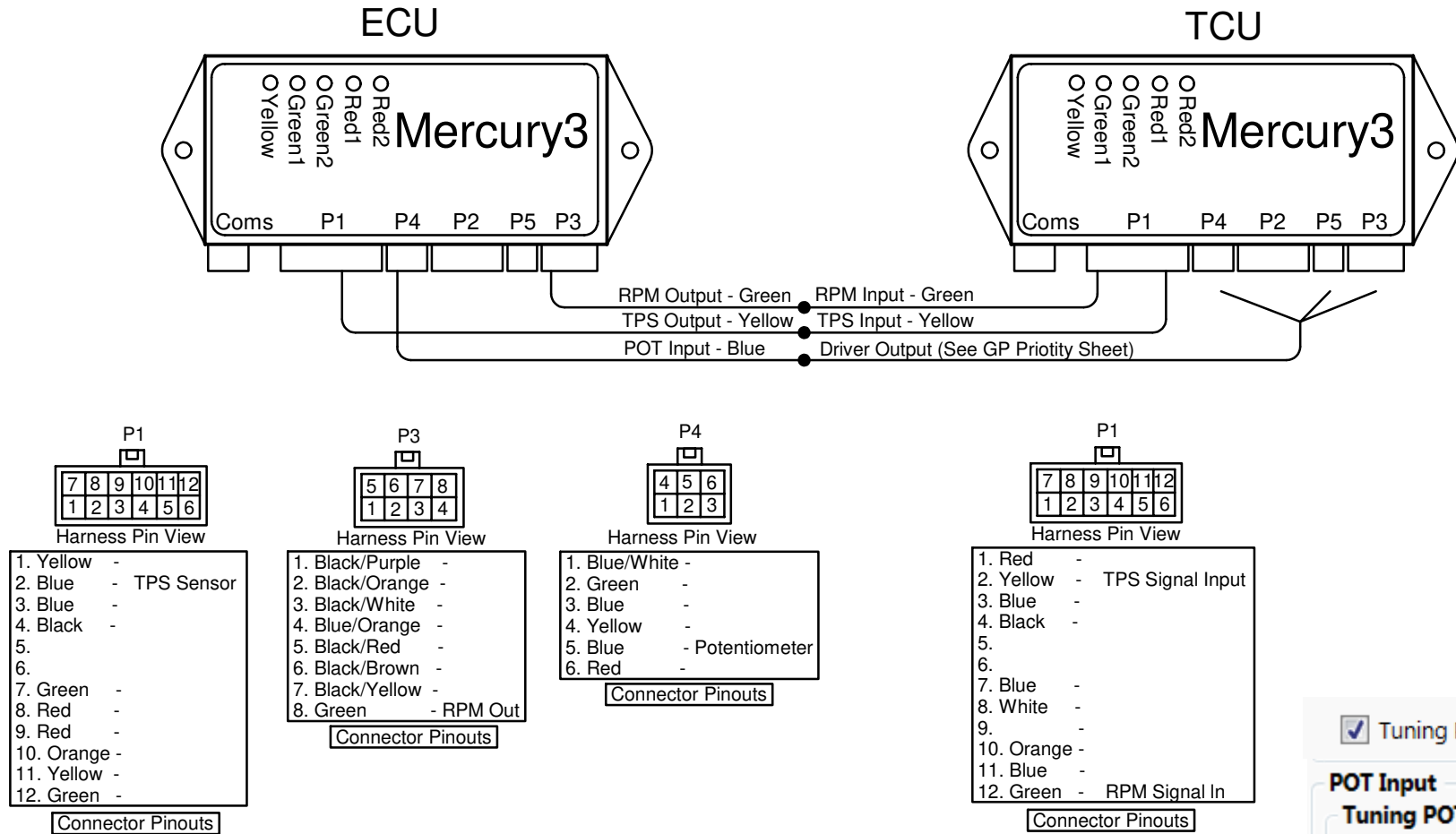

Software Settings

Tuning Pot.

**POT Input**

**Tuning POT**

Retard

POT Register 0

**Launch Control**

Timing 9 (°BTDC)

**Note:** The connection from the Mercury2 TCU changes with its GP Output Priority selection. View the Priority spreadsheet for the specific firmware to see which output is used as Retard output. It will be a negative driver.